

Mounting / user instruction DWS-120 E, DWS-160E & DFS-120E

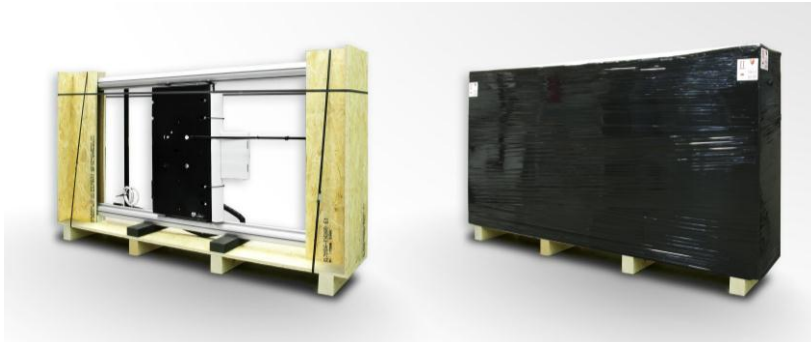

**Check at arrival the packaging to determine there's no damage to the system.
With detected damage inform your transporter in time.**



Installation of the DWS-120E / 160E & DFS-120E:

When the system is taken out of it's packaging (with care) it is important to check the following items:

- Steel cable on the motor drum (see next page).
- Proper fitting of the monitor cart between the 2 columns.

The system must be mounted to the wall, inclusive the transport security aids. This will help installing the system, keeping the product steady and strong.

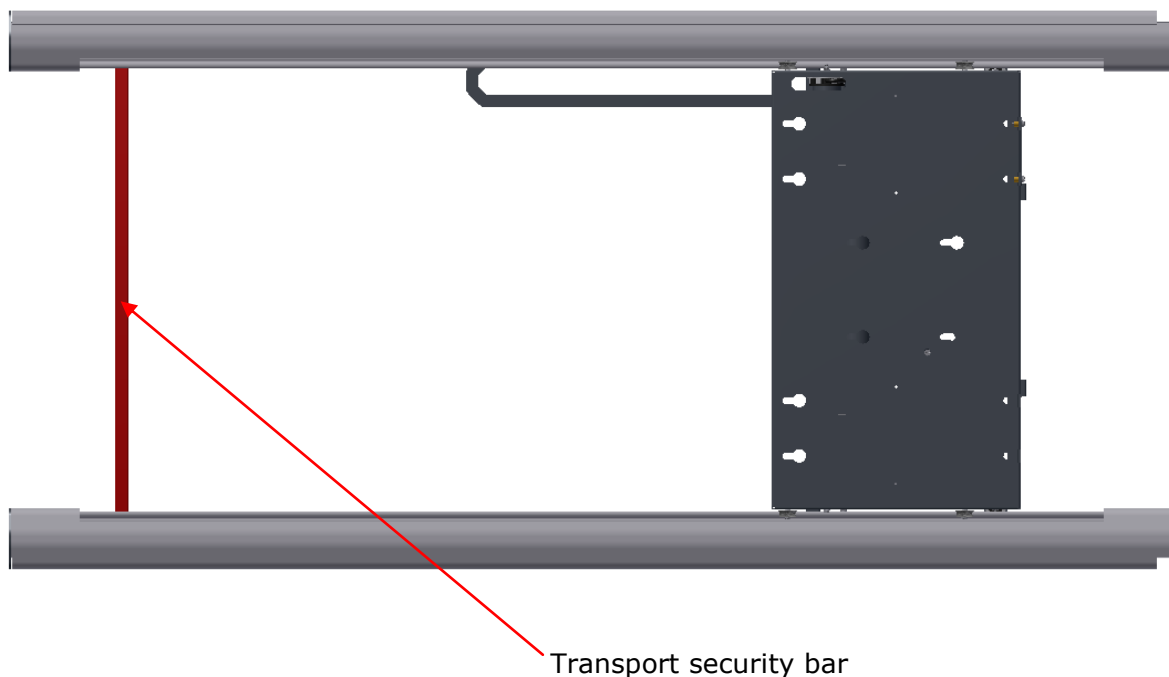

The top bar must be kept installed and may not be removed.
Only the bottom beam (red in drawing) can be removed after proper installing.
It is possible to lower the top bar, but only after setting the right end stops of the lift system (see next pages).

See the below drawing of a proper installed cable on the motor drum. The cable must be organised proper. When not, please shift the cable neatly all the way to the sides first (towards cable fastening). With the DFS system the back cover must be removed first.

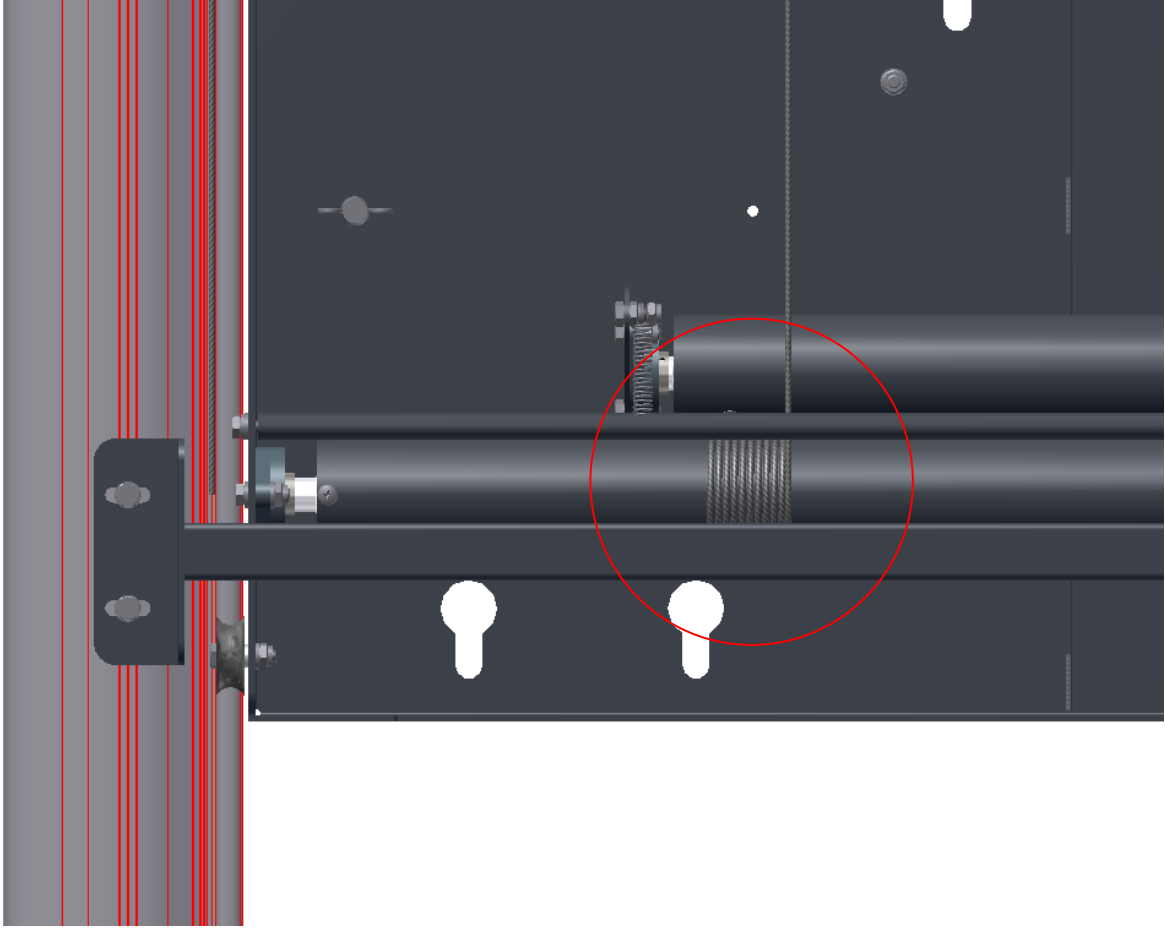

1.

Mount the system to the wall, using all applicable mounting points!
Install level and straight in all directions.
Beware that the transport aid must be maintained during the installation.



Mounting point upper left

Every mounting point has 2 bolt slots, use them at all times.
Be sure the wall is constructional capable of withstanding the forces of this system with flat panel.

It's the installers choice and responsibility to use correct fasteners.

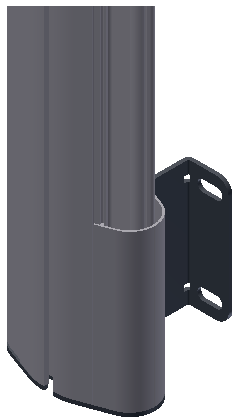
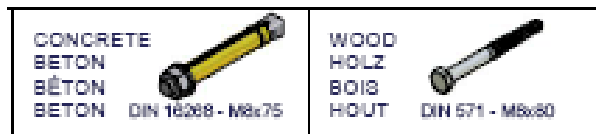

Mountingpoint lower left

2.

Install the system level in all directions.
An un-level system may result in a faulty functioning and quick ware-out of guidance.
The system must support on the floor and is not allowed to be mounted free from the floor.



When the system is installed it is possible to set the monitor cart level.
Do this only when the system has made a full travel, with load from top to bottom.

Remove the small lids from the columns and use a 13 mm wrench to correct the cable length.

Keep the stainless steel wire from rotating by holding it with pliers!

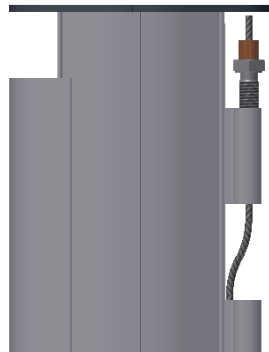

(left adjustment point)

3. The cables of the flat panel etc. can be organized in the special cable guidance.
Keep cables away from rotating parts (DWS-120E only).

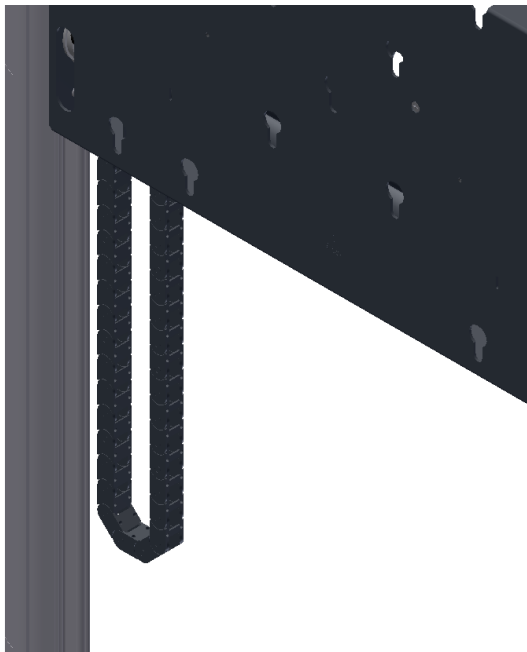

4.

When the system is installed and set, the flat panel can be installed. See the below mounting patterns with their max. mechanical loads. When the Audipack L&S5 pattern is used, please use the **UFPRO** universal flat panel mounts.

In case of using the VESA pattern, use the optional Audipack stainless steel cams for installing the flat panel directly to the system.

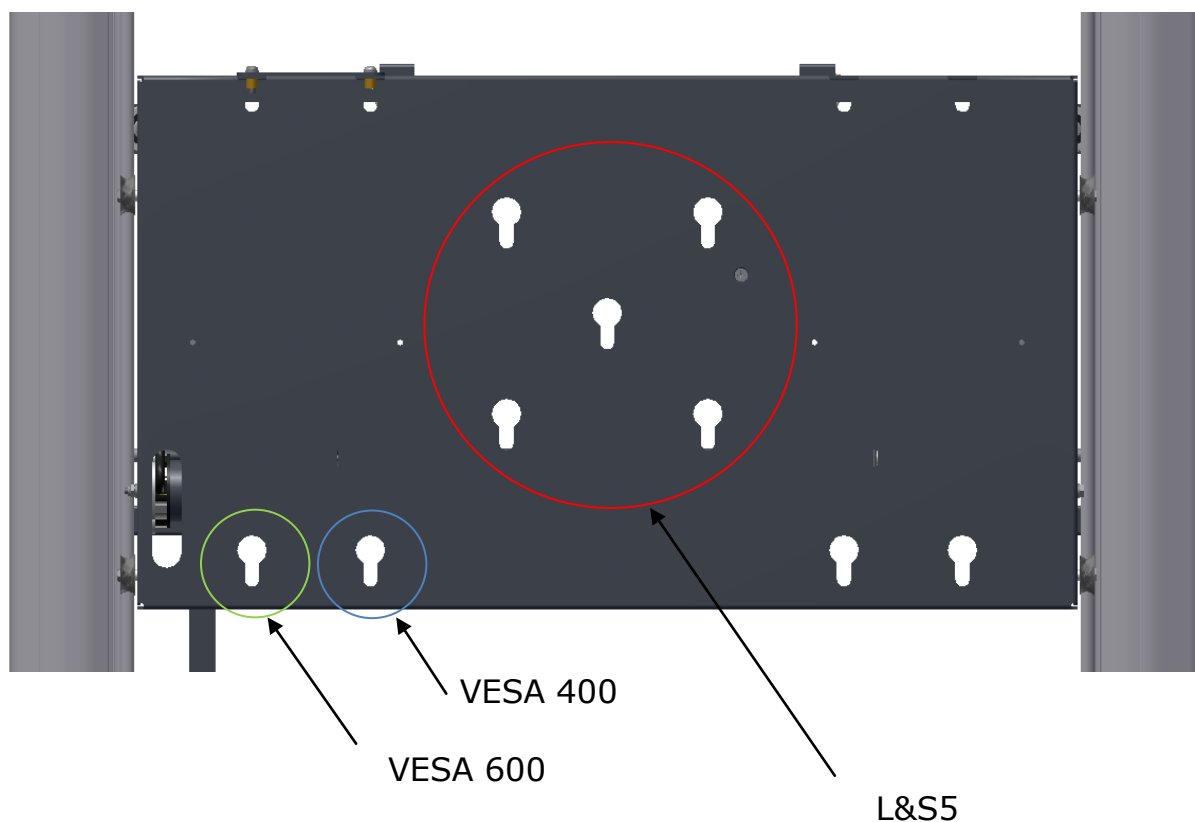

VESA 400 max. load 120 Kg
VESA 600 max. load 120 Kg, (160 Kg for the DWS-160E)
L&S5 max. load 85 Kg (i.c.w. UFPRO)

Available mounting cams:

M6 part. no 392618

M8 part. no 392318

M10 part. no 390618



5.

Flat panel security.

If needed it is possible to secure the flat panel from taking it unauthorized away.

Unlock and slide the cover panel before inserting the flat panel.
Reinstall it afterwards.

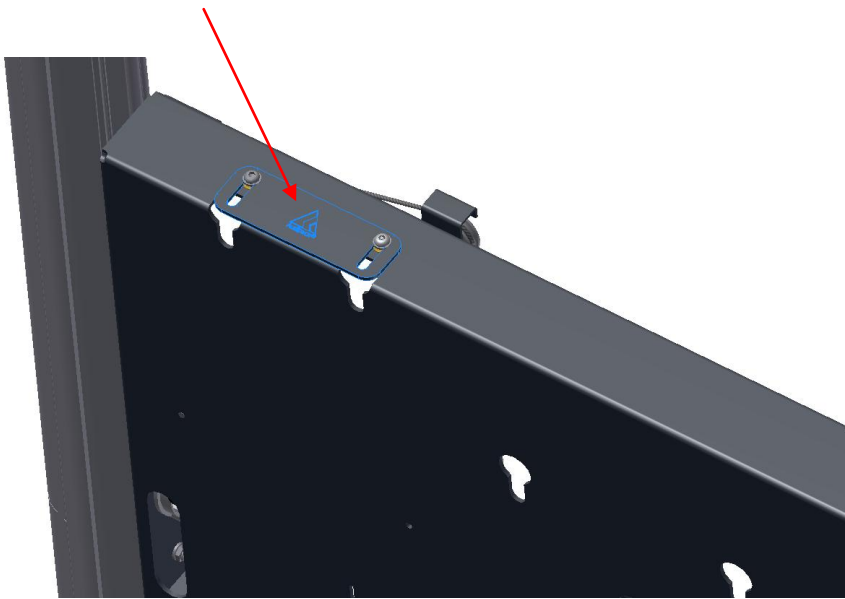

Installing the DFS-120E:



©  Audipack

(the shown model is inclusive the optional DFS-CP)

1.

The DFS-120E is the trolley version of the upper mentioned DWS system. Both systems have the same technical specifications.

2.

Remove the system from the packaging and check the content.

Do not remove the transport bar from the product until the product is completely assembled.

Mount the columns on top of the wheel base.

Be gentle with positioning so that the top of the wheel base does not get scratched.

Use only the supplied M8 bolts to fasten the set.

When the optional cover plate is applicable on the system, fasten it after fitting the columns.

Fasten the bolts firmly, but not too much. Fastening too tight may damage the windings. When installed the transport bar can be removed.

3.

Only use the system on level surfaces.

Always lock the wheels when presenting with the system and changing the screen height.



4.

The adjustments of the system are equal to the upper mentioned DWS system.

Adjusting the DWS-160E system.

Be aware that it might be possible your model is equipped with 2 version of adjustment. Please see the next chapter when the lift is equipped with an electronic height adjustment.

The difference is that the electronic version has NO yellow and white adjustment knobs as illustrated below.

When the Total system is installed please plug in the power.

The system is equipped with a wireless transmitter mounted on the back.

The system itself is already set to standard limits. Never adjust the upper limit!



At the front of the lifting head colored knobs are visible. With an allen key the positions can be set by adjusting their position.

Adjusting the upper limit:

White knob,

While giving command up adjust the white knob with an allen key. Check left and right turning for adjusting the right direction.

Adjusting lower position:

Yellow knob,

While giving command up adjust the yellow knob with an allen key. Check left and right turning for adjusting the right direction.

Attention!

When adjusting the motor limit, be aware that mechanical limits may damage the motor by setting the limits too far.

The motor can be overloaded and damage.

Max. motor running time 4 minutes.

Cooling down time 9 minutes at 4 minutes use.

Be sure that all parts move and rotate free.

Disconnect power after installation.

Connecting the DWS-160E.

Please consult the below listed diagram.

(voorbeeld besturing 261125)

(Example relay control 261125)

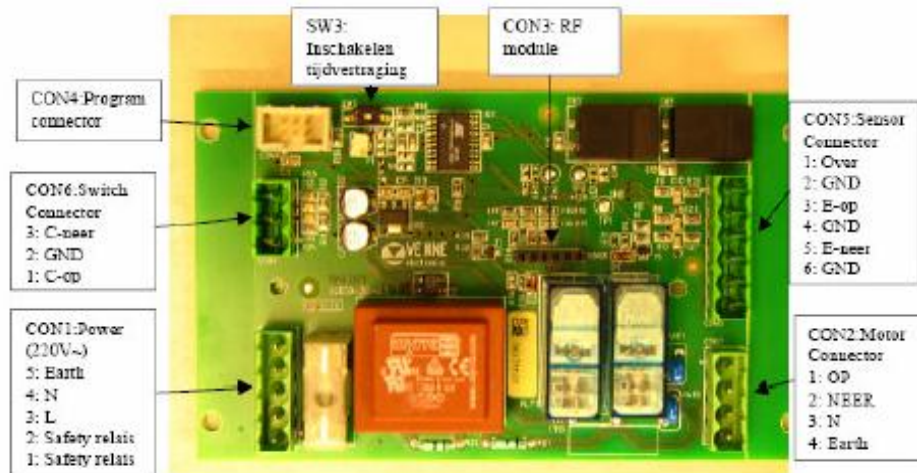

Adjusting the DWS-120E and DFS-120E system.

This procedure is only applicable for products with electronic height adjustment setting.

During testing the system is already set to maximum limits.
For the first use the lifting head must be set in height to let the cams from the monitor bracket insert into the key holes of the lifting head (while the flat panel is still in the flightcase).

Be aware of adjusting the bottom height for the DFS before installing the monitor!

Work along the below protocol to set the right height.

Adjusting new lower position (only upwards).

- Plug in power and lower the lifting head to its lower limit.
- Use the rear mounted transmitter to control the system.
- Press the buttons UP and DOWN at the same time until the mounting head moves up-and down shortly (program mode).
- Press single up to set the new height.
- For storing this position press the middle until the mounting head moves up-and down shortly.
- The new position is set.



Technical

Re-programming the control buttons (pairing).

All systems are pre-programmed in the factory.

When a new transmitter must be paired to the system check below protocol to perform the "pairing".

- Take out the transmitter from the system.
- Unplug the power for 20 seconds
- Plug in power for 10 seconds
- Unplug power for 2 seconds
- Plug back in the power, the motor will rotate for a few seconds.
- When the motor has stopped, press the small "prog" button on the back of the PCB (see picture).

Programm button

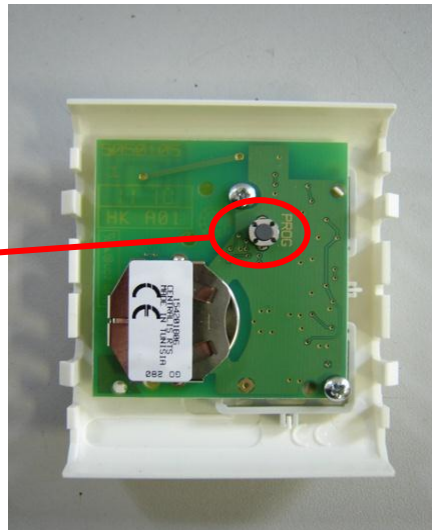

- The motor will rotate left and right shortly

Audipack

Industriestraat 2

2751 GT

Moerkapelle

+31(0)79 593 1671

Technical data:

DWS-120E, DWS-160E & DFS-120E

Maximum load:

-85 Kg with the Audipack L&S5 mounting interface

-120 Kg with the VESA 400 en 600 mounting interface (combined with the Audipack cams)

DWS-160E

Maximum load:

-85 Kg with the Audipack L&S5 mounting interface

-120 Kg with the VESA 400 (combined with the Audipack cams)

-160 Kg with the VESA 600 (combined with the Audipack cams)

Power supply 230 VAC 50-60 Hz

Max. Motor runing time 4 minutes (10 minuten "cool-down" period).

For questions and technical support please contact Audipack or the reseller:

Audipack

+31 (0)79-5931671

dept. Technicl support

Notes: