



Audipack®

It's great to have solutions...

FACT SHEET

390925



Quick Release
No tools required



3x



2724 mm



The most easy, effective and cost reducing method to assemble a video wall floor stand. No tools needed for assembling. The perfect rental product.

Free standing, dividable floor stand for a video wall of 3 flat panels of max. 55 inch per piece above one another. The quick release feature allows you to install the floor stand and screen on any location without tools.

The floor stand consists of a strong and solid vertical column, supplied with a wide access hatch on the back for power, audio and data cables.

The presentation height of the flat panel is adjustable. This floor stand is suitable for flat panels with a maximum screen size of 55 inch.

- ▲ No tools required for installation
- ▲ Easy to connect multiple floor stands to create a video wall
- ▲ Integrated yet easily accessible cable channel
- ▲ Suitable for all brands of flat panels
- ▲ Landscape and portrait orientation of the screen

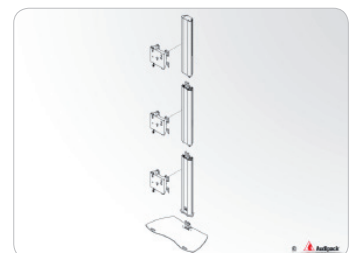



Audipack®

It's great to have solutions...

FACT SHEET

390925

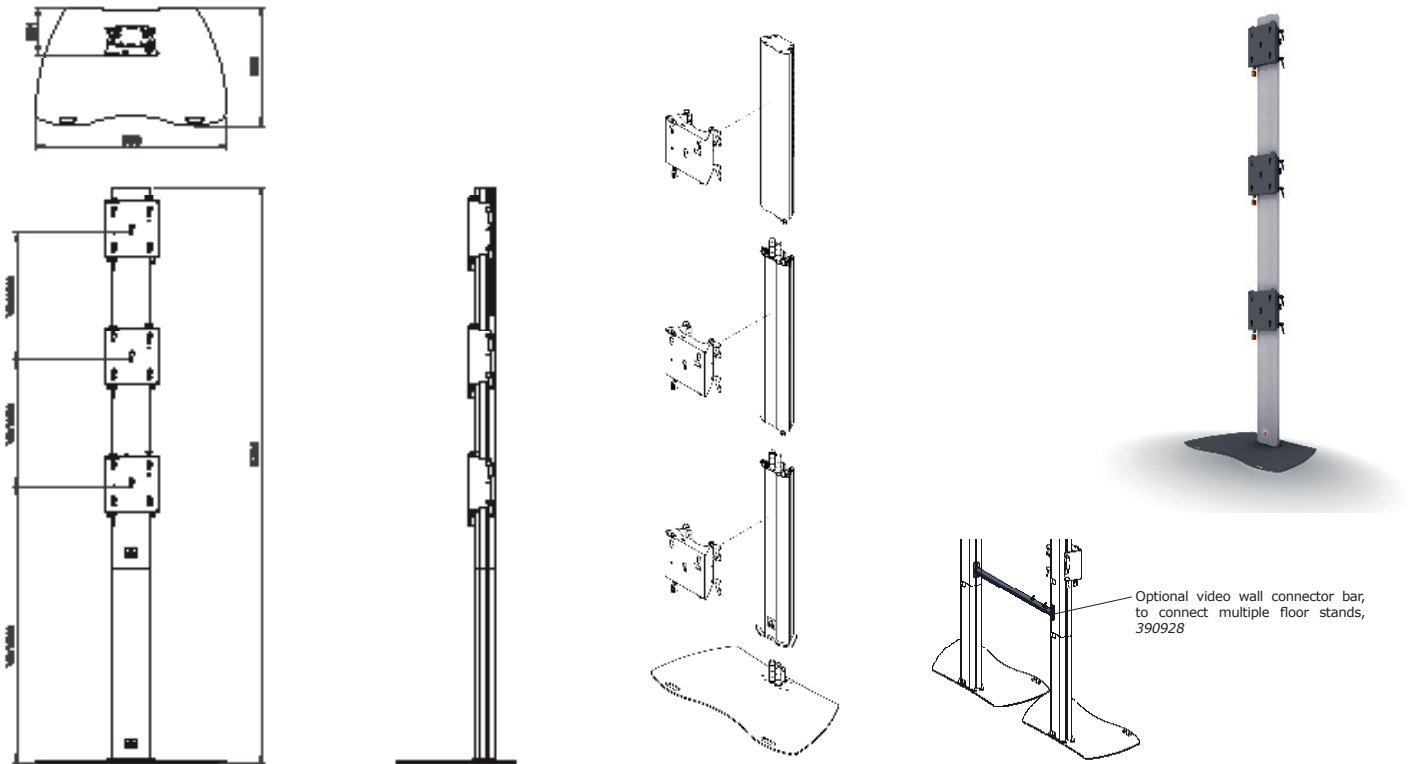

Technical specifications

Dimensions in mm	W900 x D560 x H2724
Max. screen size	3x 55 inch
Max. load	120 Kg
Mounting interface	L&S 5
Colour	Floor plate: Black, RAL 9005 Columns: Anodised aluminium
Weight	60 Kg

Optional

- Mounting bracket (required for screen installation)
universal models and brand related models available
- Video wall connector bar, to connect multiple floor stands, 390928
- Flightcase for safe transport of the floor stand and screen
- Laptop supports, 390915, 390916
- Laptop housings, 390937
- Equipment cabinets, EC-935, EC-936
- Mounting head for multiple screen installation, 390951
- Video conference mounting head, 390969, 390970
- Portrait/Landscape adapter, P3496
- Lock for protect the screens against theft, 230052